

PHOENIX ENGINEERING DRAWING

THE SPECIFICATIONS HEREIN ARE NOT EXPRESS WARRANTIES NOR REPRESENTATIONS WHICH SHOULD BE RELIED UPON BY THE PURCHASER. THE SAME ARE PRESENTED FOR PURPOSES OF DISCUSSION ONLY AND FINAL DIMENSIONS ARE NOT BASED UPON THE SAME.

ThermoSpas

Hot Tubs • Chemicals • Service
155 EAST STREET • WALLINGFORD, CT • 06492
(203)265-6133 Main Voice
(203)265-7133 Main Fax
(203)296-3691 Service Fax

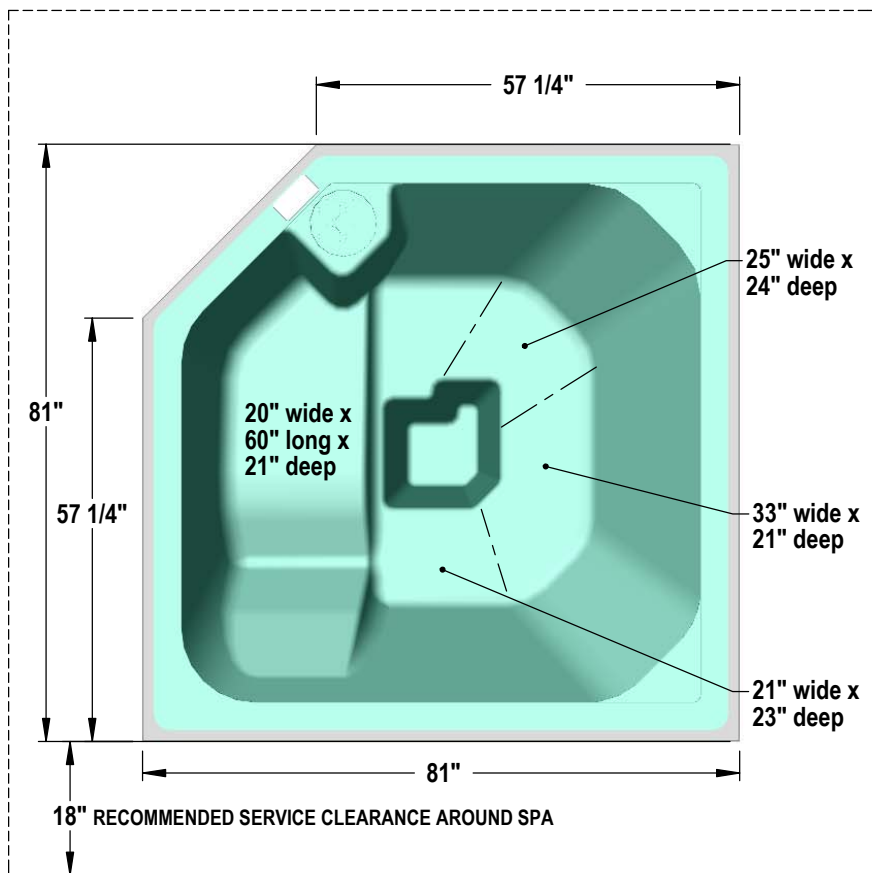

NOTE: Depth is measured vertically from top of spa coping to deepest part of seat. Seat width is measured at hips.

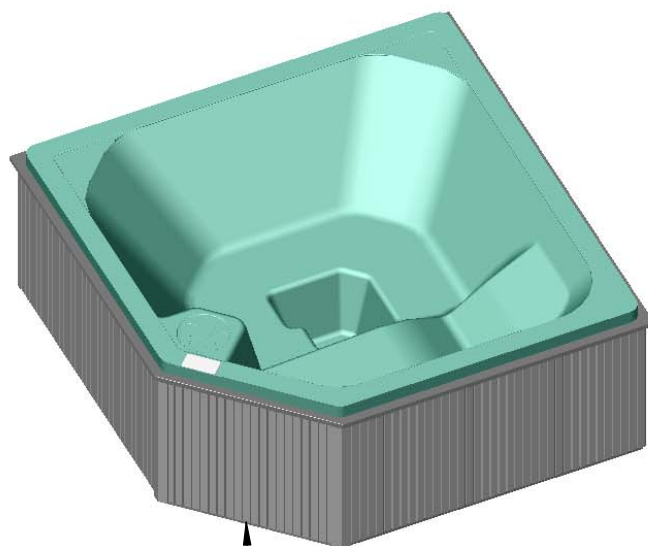

Spa Pak Located Behind This Panel

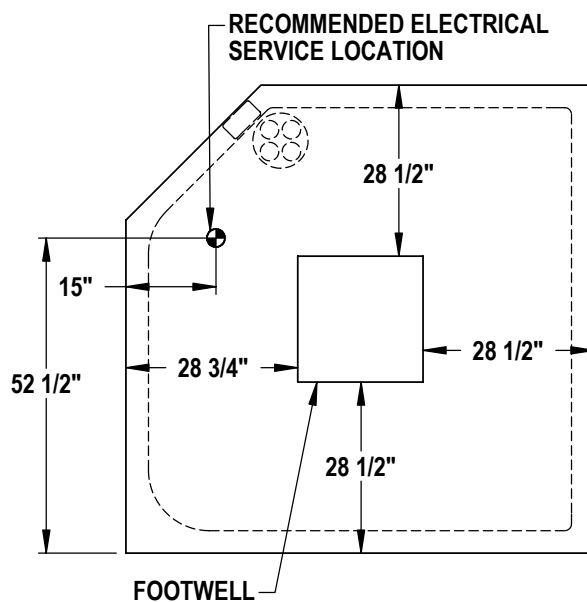
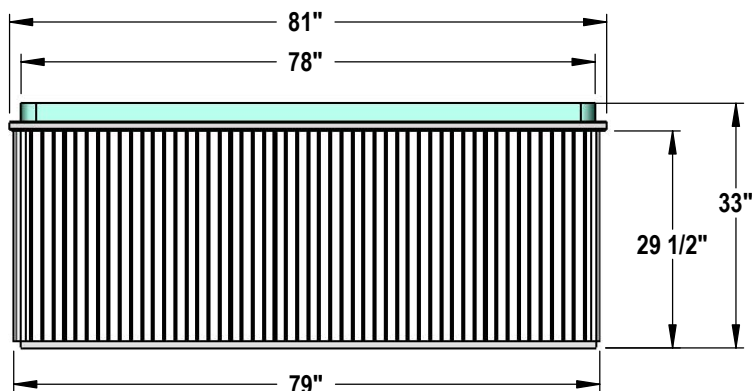

Crated Dimensions	85-1/2 x 85-1/2 x 39
Capacity (Gallons)	215 / 310 (usage level / full to brim)
Shipping Weight (lbs.)	710
Weight (Filled)	2,500 lbs.

CERTIFIED TO UL 1563 - ETL REPORT #3044827-LST

REVISED 5-11-04