

RTA STEP ASSEMBLY INSTRUCTIONS (2 TIER / OPEN)

Your RTA STEPS consist of (1) LEFT STRINGER, (1) RIGHT STRINGER, (1) CENTER STRINGER, (4) TREAD SLATS, (24) 1" x 1/2" MOUNTING BRACKETS, (48) #10-32 x 3/4" SELF-DRILLING SCREWS and (10) #10-32 x 1" OVAL-HEAD SCREWS, as shown in FIGURE 1 at right. A phillips head screwdriver is the only tool required for assembly.

STEP 1

Using (24) #10-32 x 3/4" SELF-DRILLING SCREWS, attach the 1" x 1/2" MOUNTING BRACKETS to the CENTER, LEFT, and RIGHT STRINGERS. The LEFT and RIGHT STRINGERS each have 8 dimples indicating the locations of the screws. The CENTER STRINGER has 8 dimples on each side for 16 MOUNTING BRACKETS. Do not completely tighten any screws at this time. See FIGURE 2 and DETAIL 1 below.

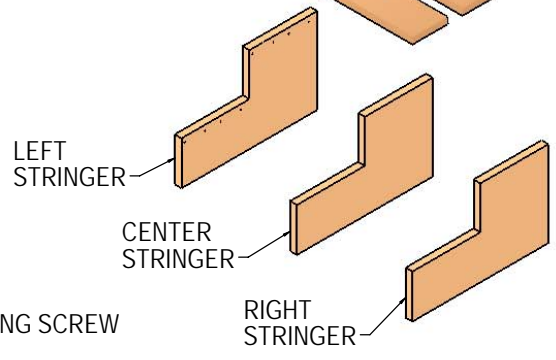
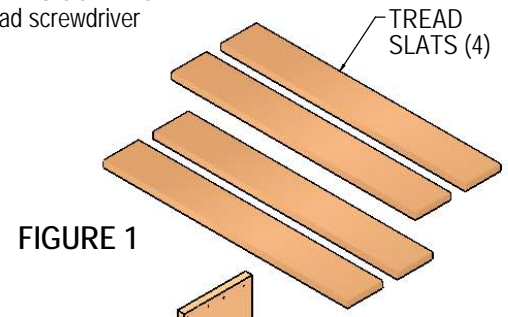
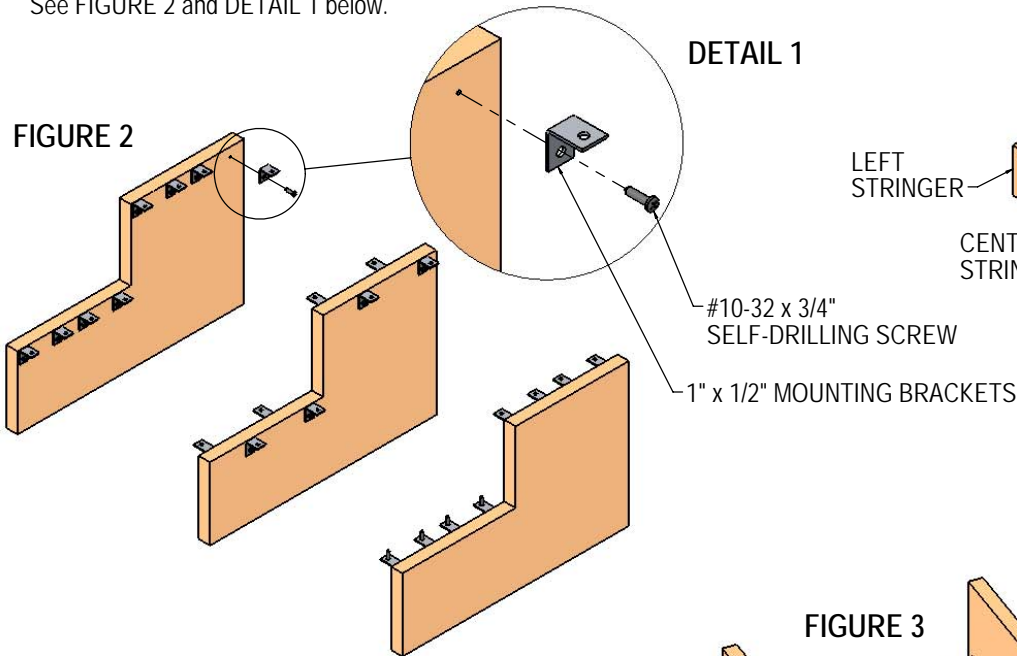

STEP 2

Attach the (4) TREAD SLATS to the LEFT, RIGHT, and CENTER STRINGERS with the remaining (24) #10-32 x 3/4" SELF-DRILLING SCREWS by aligning the locating dimples in the underside of the TREAD SLATS with the holes in the (24) 1" x 1/2" MOUNTING BRACKETS installed in the previous step, as shown in FIGURE 3 and DETAIL 2. Tighten all screws at this time to complete assembly.

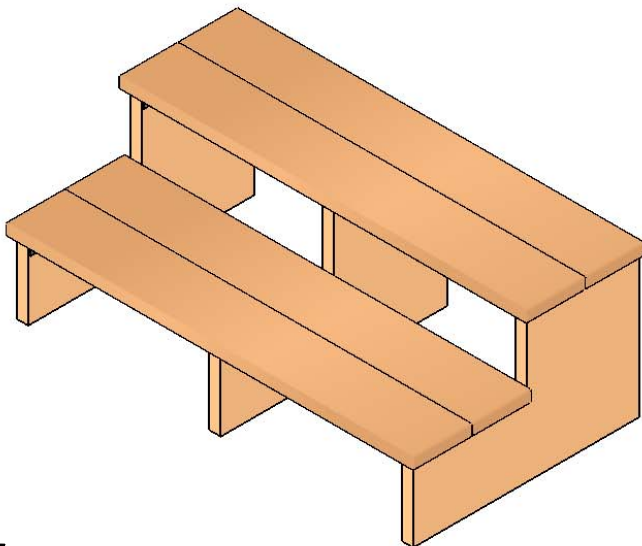
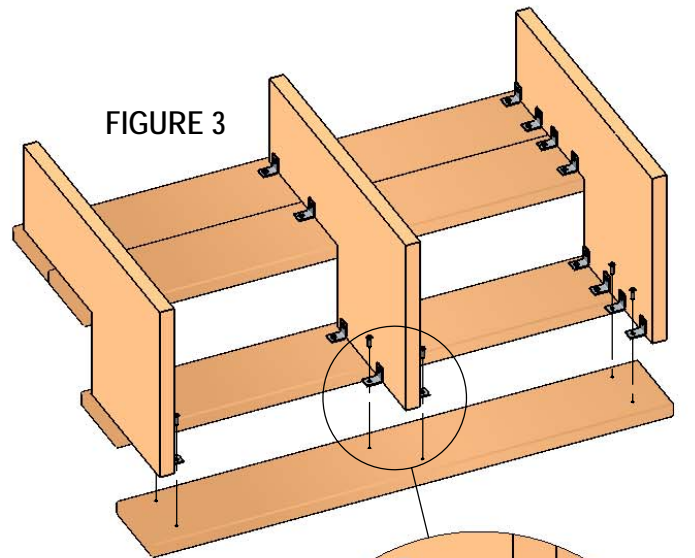

COMPLETED ASSEMBLY